

PORTABLE RCC MIXER



CONCRETE PLANTS • Tompkinsville, KY

800-626-0200

www.stephensmfg.com



MIXER COMPONENTS



The full width access hatch allows easy access. It includes two inspection ports and a high security positive disconnect lock.

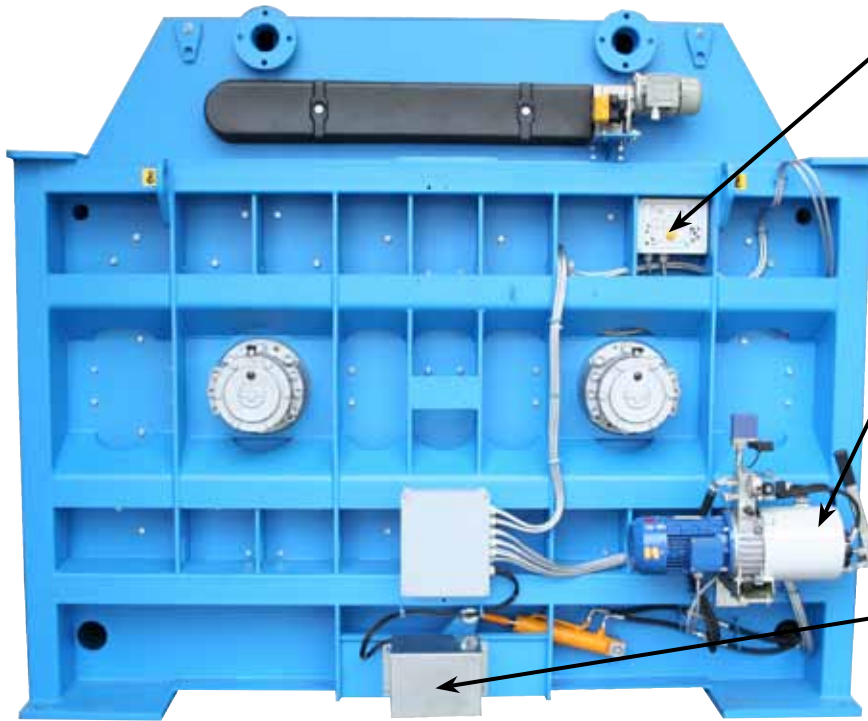

The **Alarm Unit** is standard and warns of faulty shaft seal lubrication, low oil levels and high temperatures in gearboxes and motors.

The **Sicoma Strength** discharge door is hydraulically powered. A manual lever allows the door to be opened if power is lost.

The Sicoma Strength waterproof door does not leak. A Non-rubbing positive closing action with both pressure and position switches, plus an adjustable part-open position and rubber seals give many years of life.

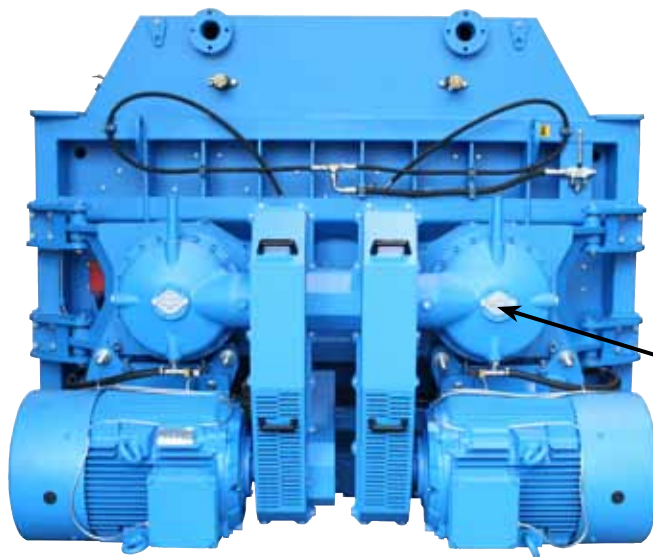

SWING OUT DRIVES:

The full drive assembly (motor, pulleys and gearbox) is hinged to the frame of the tank. In case of maintenance to the shaft supports, this system guarantees the fastest accessibility. The downtime is at least one third of any other twin shaft mixer.

SHAFT SEALS:

The new shaft seals by SICOMA are mechanical seals based on the rotation of two high precision top hardness rings.

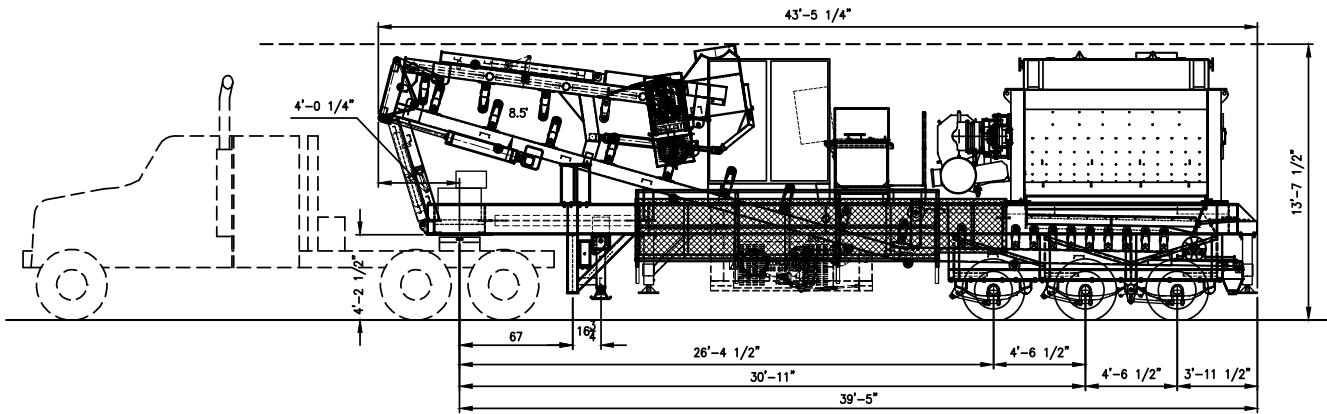

SHIPPING VIEW: RCC MIXER ON TRAILER & CONVEYOR FOLDED OVER

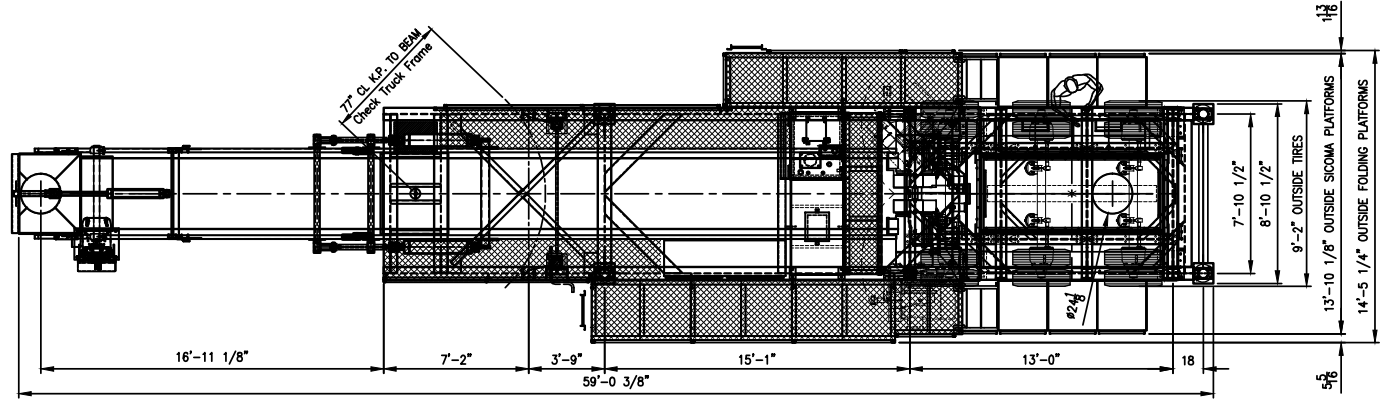

PLAN VIEW: RCC MIXER & CONVEYOR IN OPERATION POSITION

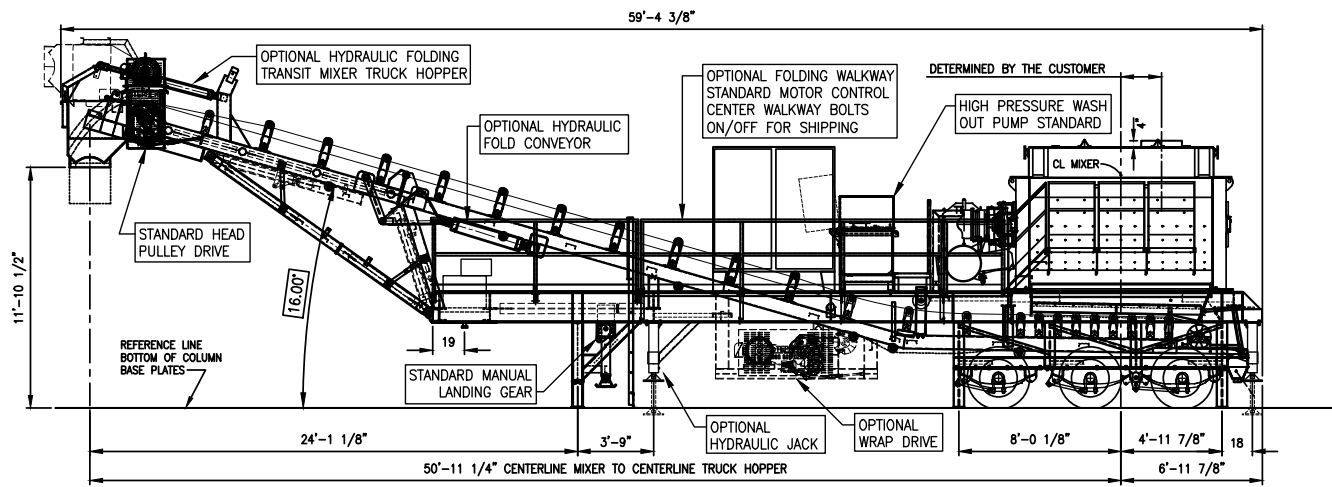

SIDE VIEW: PORTABLE RCC MIXER SYSTEM WITH 42" BELT X 54'-0" LONG CONVEYOR

PLANT CLEARANCE OF 13'6" (MIN.) REQUIRED

PORTABLE RCC MIXER

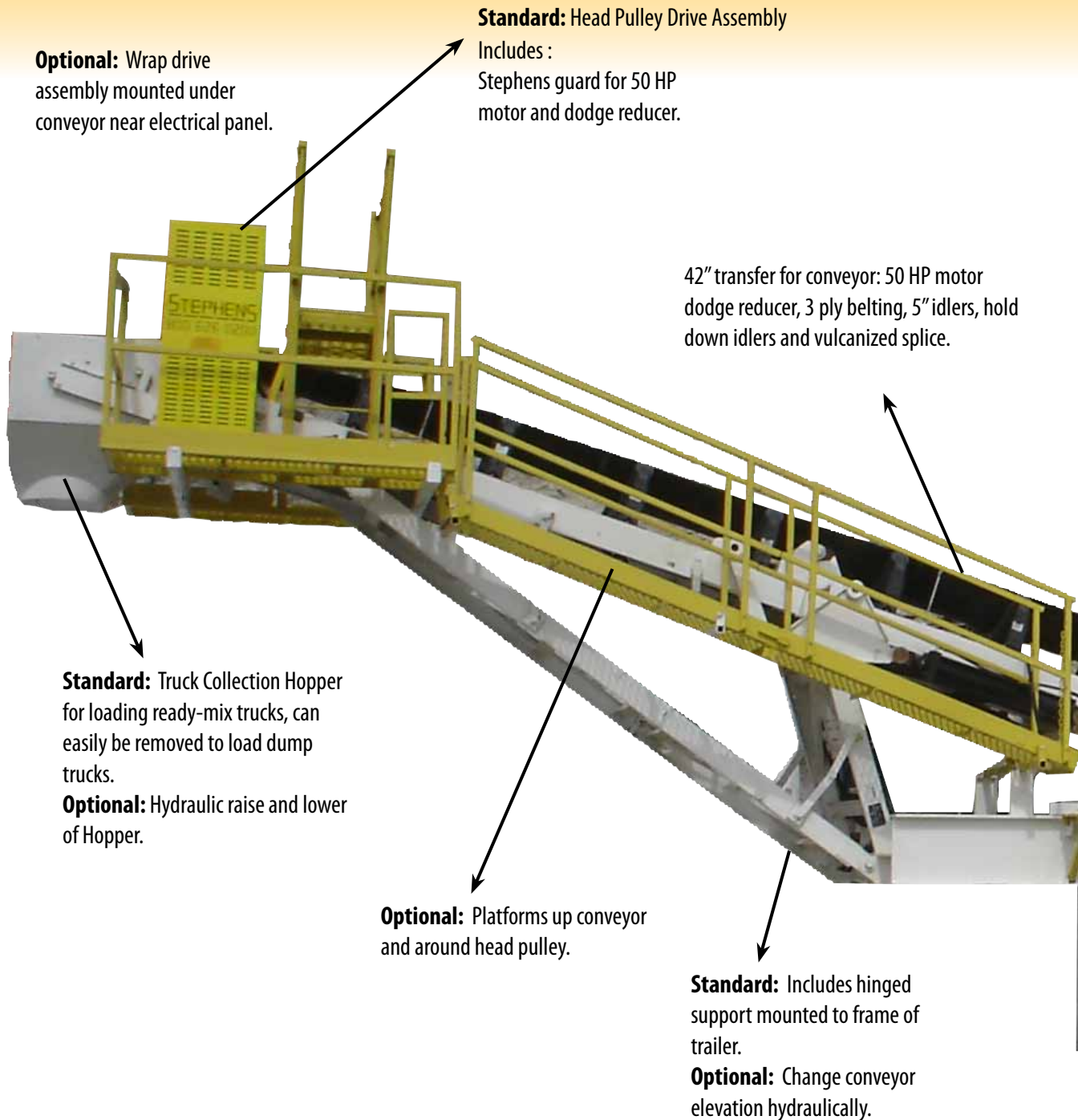

Optional: Wrap drive assembly mounted under conveyor near electrical panel.

Standard: Head Pulley Drive Assembly

Includes :
Stephens guard for 50 HP motor and dodge reducer.

42" transfer for conveyor: 50 HP motor
dodge reducer, 3 ply belting, 5" idlers, hold
down idlers and vulcanized splice.

Standard: Truck Collection Hopper
for loading ready-mix trucks, can
easily be removed to load dump
trucks.

Optional: Hydraulic raise and lower
of Hopper.

Optional: Platforms up conveyor
and around head pulley.

Standard: Includes hinged
support mounted to frame of
trailer.

Optional: Change conveyor
elevation hydraulically.

Hydraulic Options:

Gas Power Pack , Leveling Jacks, Conveyor Fold/
Unfold

Electric Power Pack:

Leveling Jacks, Conveyor Fold/Unfold, Hopper Fold,
Conveyor Elevation Controls

Our motor control center is complete with starters and controls for the conveyors and Sicoma mixer. Equipment is also pre-wired to starters in liquid tight metallic flex conduit.

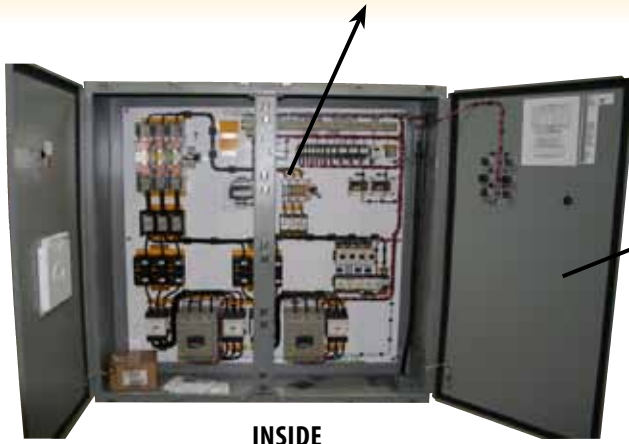

3rd party UL and CSA Approved

Sicoma twin shaft mixer MAO-6,000 with automatic high-pressure washout system. Optional sizes available.

INSIDE

ELECTRICAL PANEL



Bolt on removable expanded metal work platform for access to motor, control center pumps and mixer.

Heavy duty frame. Designed for twin shaft or continuous mixers. Shown with Sicoma MAO-6000 twin shaft mixer. Includes three (3) 20,000 lb. single axle transportation systems, with air brakes, turning signals and 5th wheel.

TOWABLE POSITION



The Sicoma Strength extra-rigid frame holds the mixer shape and maintains shaft alignment during heavy mixing. This helps to prevent damage and keep you up and running year after year.

The Sicoma Strength design concentrates the compulsory mixing action in the center of the mixer, giving a more homogenous mix in faster times. It also uses up to 15% less cement — a huge savings for most applications.

A one day shaft replacement — Sicoma understands that if you are not mixing concrete, you are not producing. We have designed our shafts to be able to be changed in one day (if you ever need to), saving you time and money.

The standard **High Pressure Washout** eliminates most of the clean up. The powerful pump and twin oscillating spray bars create powerful jets of water in the mixer. These jets and a hand gun makes cleaning tough corners easy.



| MODEL MAO | 6000 | 7500 | 9000 |
|--|--------------|-------------|-------------|
| Yield compacted concrete, cu. yd./cu.m. ^{1.} | 5.3/4.0 | 6.6/5 | 8/10.5 |
| Time per cycle (loading included) seconds ^{2.} | 90 | 90 | 90 |
| Compacted concrete per hour, cu. yd./cu.m. ^{2.} | 213/160 | 267/204 | 330/244 |
| Mixing motors and power, HP / kw | 2x100/75 | 2x125/90 | 4x75/55 |
| Hydraulic power pack motor, HP/kw | 3/2.2 | 3/2.2 | 10/7.5 |
| Mixing shaft speed, rpm (varies between) | 24-27 | 24-27 | 24-27 |
| Number of mixing arms | 24 | 24 | 32 |
| Maximum aggregate size, inches / mm | 7/180 | 7/180 | 7/180 |
| Weight of empty mixer (without skip), lb / kg | 26,240/11900 | 26450/12000 | 31200/14200 |

1. Maximum 150 lb/FT³

2. Cycle time and capacity rate may vary based on mix designs.



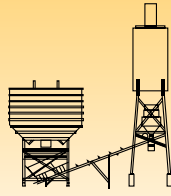

Stephens

CONCRETE PLANTS • Tompkinsville, KY



NOTE: All technical data subject to change without notice due to technical improvements.



Stephens Manufacturing

P.O. BOX 488 • TOMPKINSVILLE, KY 42167

PHONE: 800-626-0200 • OUTSIDE the USA 270-487-6774

FAX: 270-487-8368

www.stephensmfg.com

Proud Members of:

